

## MAGNETIC MARK INTENSIFIER AMS5A105



### TABLE OF CONTENTS

<u>SECTION</u>	<u>DESCRIPTION</u>
1.0	GENERAL DESCRIPTION
2.0	MOUNTING AND OPERATING PROCEDURES
3.0	SPECIFICATIONS, DRAWINGS AND PARTS LISTS

## 1.0 GENERAL INFORMATION

### 1.1 Device description

This device is designed to automatically install new magnetic marks on the wireline directly over old weaker marks that have been previously installed.

It has a built in mark detector that looks for a valid magnetic mark then replaces that mark with a stronger one.

It rides on the wireline next to the measuring head. A mount is provided to attach the device to the measuring head to keep it in place.



The device will intensify marks going either in or out of the well.

The intensifier will output a 15ms pulse when the “center” of a magnetic mark is detected. The software defines the center of the mark as the point at which the differential signal moves 3% of the DAC differential full-scale output signal or more from the peak of the differential signal.

During operation, the Intensify light will blink one time if the detected mark is at a low level (approx. 1 gauss). The Strong Mark light will also blink which indicates that the mark has been intensified.

A medium strength mark will cause the Intensify Light to blink two times. The Strong Mark light will also blink which indicates that the mark has been intensified.

A strong mark (approx. 4 gauss) will cause the Intensify Light to blink three times. The Strong Mark light will not blink which indicates that the mark has not been intensified.

On power up the device will run through a POST (power on self test). All 3 lights should light up. The Strong Mark light should then go out. The Intensify Light should remain lit while the device is performing an internal zero. After the zeroing is complete it should also go out. Any other behavior indicates an internal error in the device.

This device is not intended to replace the need for a marking job where the cable is degaussed and new marks added but for lengthening the life of the marks between marking jobs.

If there are missing marks on the cable the intensifier will not install new marks in place of the missing marks. The cable must be remarked in this case.

It is important to have the cable periodically degaussed and remarked because the wireline is constantly stretching. This device is recommended for use only with a seasoned cable since a new cable will stretch much more than a seasoned cable.

## 2.0 INSTALLATION AND OPERATING PROCEDURES

### 2.1 Install the measuring head mount to the end of the AM5K measuring head.

The AM5K mount is designed to bolt to the end of the measuring head frame. It then is attached to the magnetic mark intensifier device using a locking pin.

AMS5M024

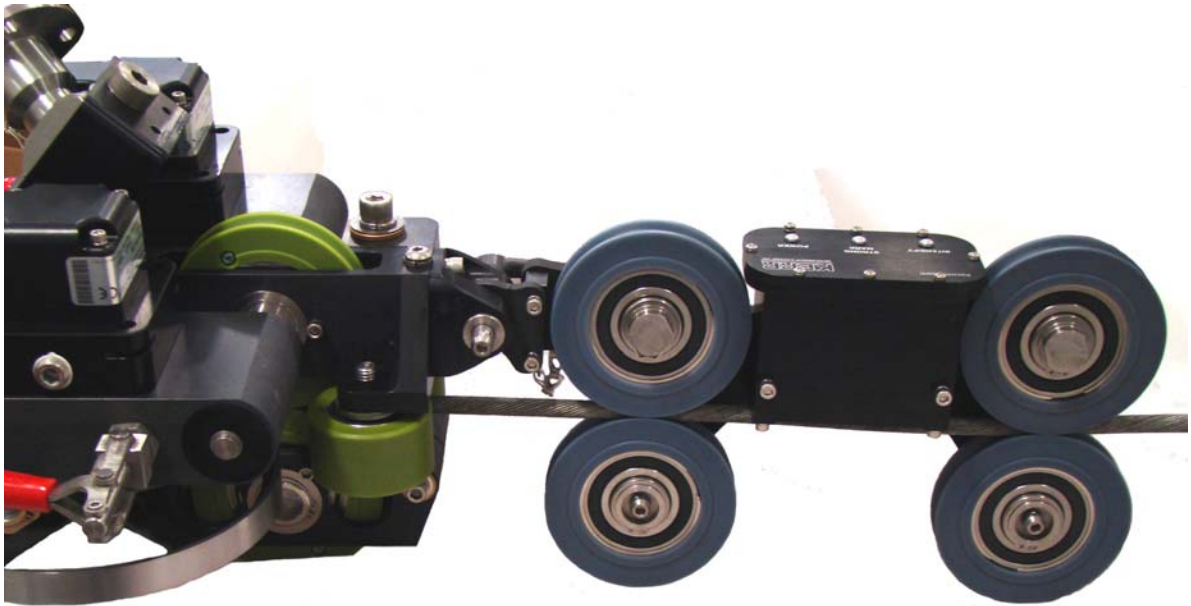
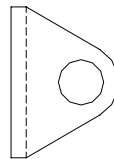

### 2.2 Connect the power cable.

Install the AMS5A018 cable in the logging unit. Connect pin A to +12/24 vdc and pin B to ground.

Run the cable along the spooling arm so it reaches to the point where the mark intensifier will be mounted.

**2.3 Remove the pins from the bottom two wheels of the mark intensifier and rotate the wheels down.**

Attach the device to the measuring head by inserting a pin through the measure head mount and end hole in the mark intensifier assembly.

Place the wireline cable between the top and bottom wheels.  
Reinstall the pins in the bottom two wheels to secure it in place.

When you are ready to start intensifying marks, plug the power cable into the device. The POWER led should turn on.

The unit is now ready to operate. As the cable passes under the device the marks will automatically be intensified as necessary.



### 3.0 SPECIFICATIONS

3.1 WEIGHT                    19 LBS                    8.6 KG

### 3.2 DIMENSIONS

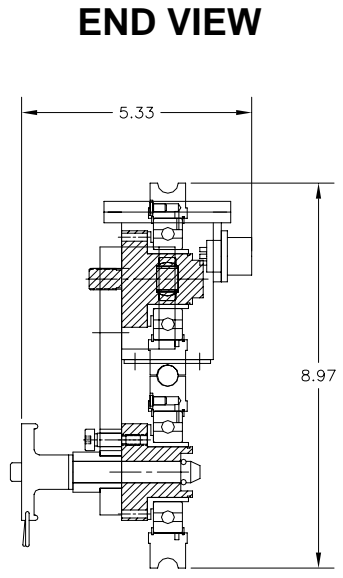
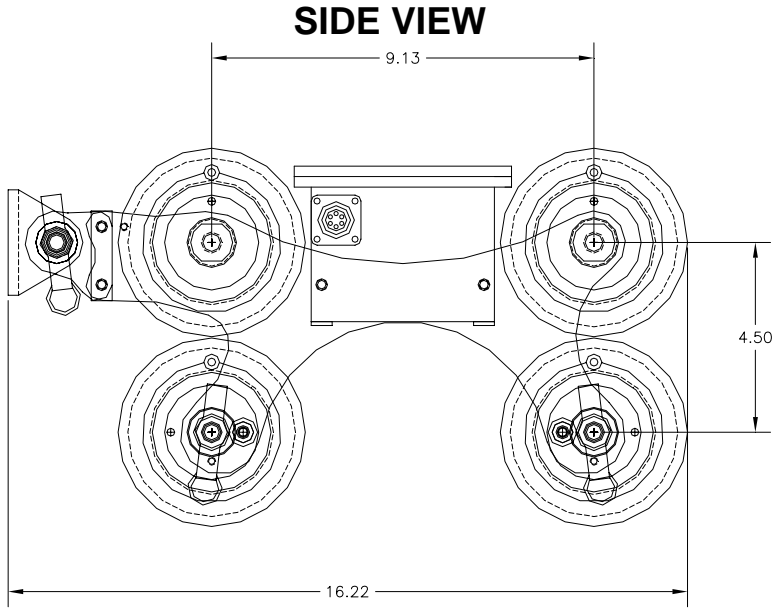

## 4.0 DRAWINGS AND PARTS LISTS

### 4.1 MECHANICAL ASSEMBLY DRAWINGS

**SIDE VIEW (FRONT)**

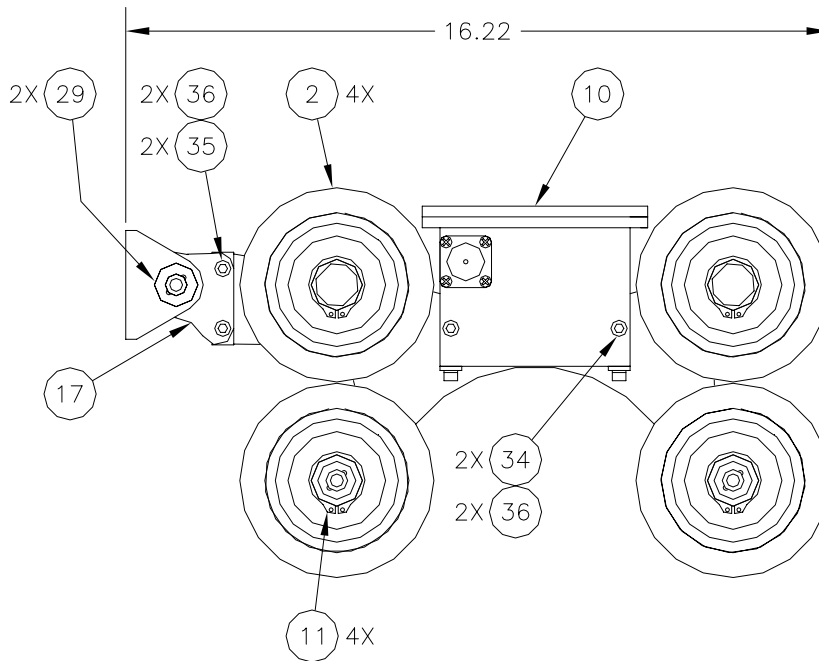

**SIDE VIEW (REAR)**

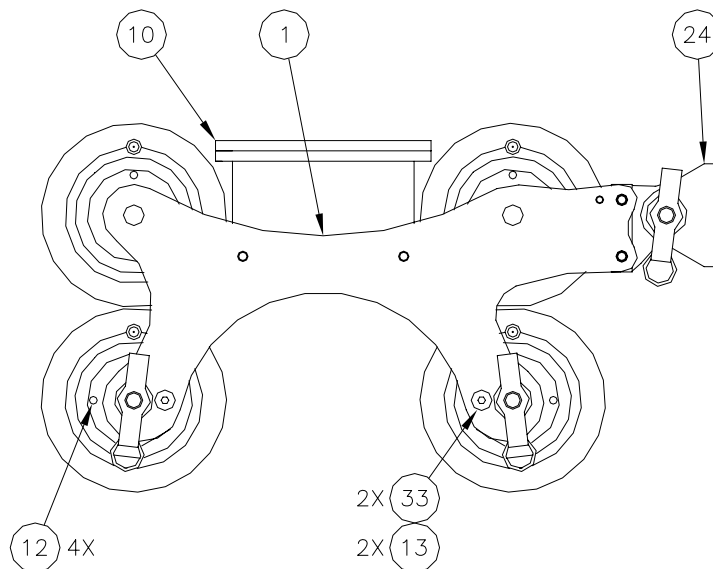

**TOP VIEW**

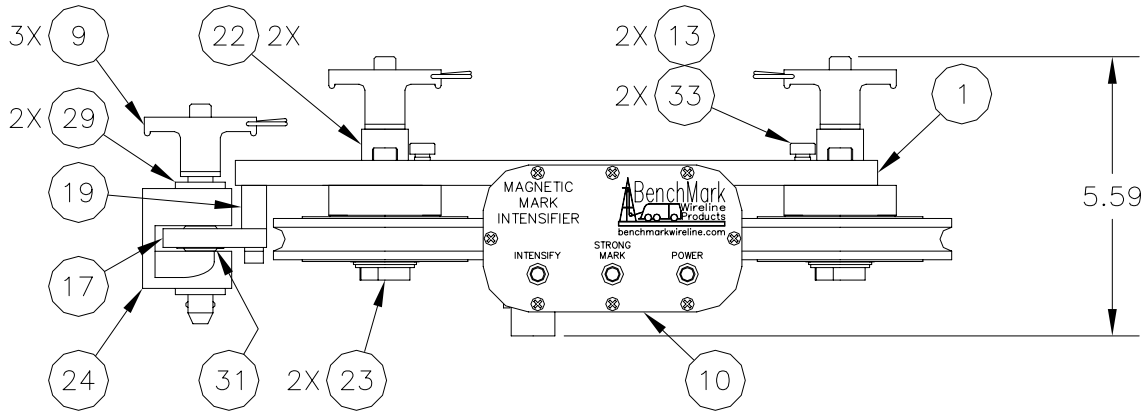

**END VIEW**

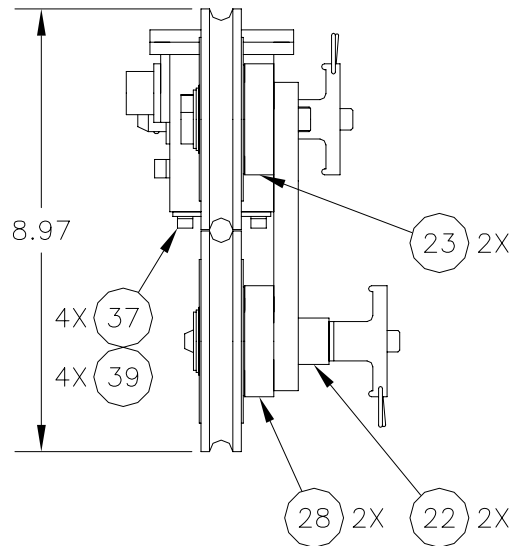



## 4.2 MECHANICAL ASSEMBLY BILL OF MATERIALS

Item Number: AMS5A105

DEVICE INTEG MAG MARK INTNSFR

Component	Description	Qty	Ref
AMS5M030	FRAME SIDE MAG MARK INTENSIFR	1	EA
AM5KA137	ASSY WHEEL GUIDE PLAS 35MM BRG	4	EA
AMS1P009	PIN QUICK REL 1/2 OD X 2-1/2	3	EA
AMS5A010	COIL ASSY MAG MARK INTENTENSFR	1	EA
AM3KP018	RING RETNG EXT 1.188 SHAFT SST	4	EA
AM5KP125	PIN COILED SPRING 3/16 X 1/2	4	EA
AMS5P013	BEARING BRZ .314 ID X .503 OD	2	EA
AMS5M017	EYE FRAME MAG MARK INTENS	1	EA
AMS5M019	SPACER EYE FRAME MAG MARK INT	1	EA
AMS5M042	BUSHING FLANGE LWR WHEEL MMI	2	EA
AMS5M123	SHAFT ROLLER UPPER 30MM X 2.64	2	EA
AMS5M024	CLEVIS MOUNT END MMI TO AM5K	1	EA
AMS5M138	HUB GUIDE WHL 30MM LWR MMI	2	EA
AMS5M059	BUSHING FLANGE QUIK PIN MMI SS	2	EA
AM5KP075	CHAIN SASH #35 SST	18	IN
AM3KP031	BEARING SPHERICAL 1/2" ID	1	EA
AMS5P053	BOLT SHOULDER 5/16 X 5/8 SST	2	EA
AMS5P016	SCREW 1/4-20 X 2-3/4 SOC HD SS	2	EA
AM3KP029	SCREW 1/4-20 X 1-3/4 SOC HD SS	2	EA
AM5KP144	WASHER 1/4 LOCK SS HIGH COLLAR	4	EA
AM5KP040	SCREW 10-24 X 3/8 SOC HD SST	4	EA
AMS1P052	SCREW 10-24 X 5/8 SOC HD SST	3	EA
C276P035	WASHER #10 LOCK SS	3	EA
AM3KP057	SCREW 5/16-18 X 1-1/4 SOC HD	2	EA
AM5KP187	WASHER 5/16 LOCK SS HI COLLAR	2	EA

### 4.3 AMS5A018 CABLE ASSY

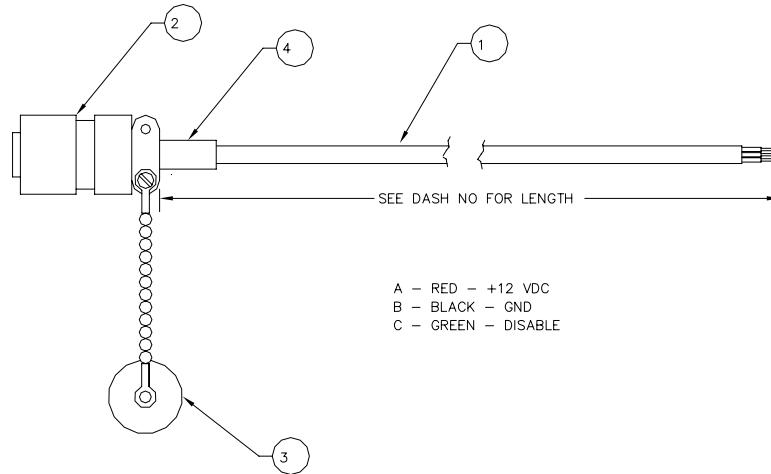

Item Number: AMS5A018-30      CABLE MAG MARK INTENSIFIER

Component	Description	Qty Required
AMS4P222	CABLE 20/4C ALPHA 25154 BLACK	30 FT
AMS1P037	CONN MS3106F-14S-6S CABLE TO	1
AMS7P042	DUST CAP MS25042-14DA	1
AM5KA034	BUSHING #9779-513-4 AMPHENOL	1
ACMU1P88	TUBING SHRINK 1.00 ADH LINED	1

***GROUNDING PIN C DISABLES THE MARK DETECTOR. THIS CAN BE USED TO PROVIDE A DISCRIMINATOR TO KEEP NOISE FROM BEING DETECTED AS A MARK.***

ELECTRICAL ASSEMBLY BILL OF MATERIALS

Item Number: AMS5A010 COIL ASSY MAG MARK INTENTENSFR

Component	Description	Qty Required	UM
AMS5M010	HOUSING MAG MARK INTENSIFIER	1	EA
AMS5M011	COVER MAG MARK INTENSIFIER	1	EA
AMS5M012	CLAMP COIL MAG MARK INT	2	EA
AMS5A013	COIL WINDING MAG MARK INTENS	1	EA
AMS5M014	PLATE WEAR MAG MARK INTENSIFR	2	EA
AMS5M052	CLAMP DETECTOR MAG MARK INT	1	EA
AMS4P760	LIGHTPIPE 5/16 X 0.32 SEALED	3	EA
AMS5P012	INSERT CLINCH STANDOFF 6-32 X	4	EA
AMS4P198	SPACER UNTHREADED RND NYLON #4	0	EA
AMS5P037	O-RING 2-240 BUNA N 70D	1	EA
AMS5P038	O-RING 2-018 BUNA N 70D	1	EA
AMS7P041	DUST CAP MS25043-14DA RECEPT	1	EA
C276P043	CONN MS3102E-14S-6P LOAD AXLE	1	EA
AMS5A037	CABLE ASSY POWER MAG MARK INTN	1	EA
AMS5A038	CABLE ASSY DETECTOR MAG MRK IN	1	EA
AMS5A039	PCB ASSY MAG MRK INTNSFR CNTRL	1	EA
AMS5A040	PCB ASSY MAG MRK DETECT INTENS	1	EA
AM3KP054	SCREW 10-24 X 1 SHCS SST	2	EA
AMS1P054	WASHER #10 FLAT SS	2	EA
C276P035	WASHER #10 LOCK SS	2	EA
FSU1P033	SCREW 4-40 X 1/2 PHIL PAN SST	8	EA
AMS8P036	WASHER #4 LOCK SST	8	EA
AMS1P040	SCREW 6-32 X 3/8 PHIL PAN SST	6	EA
C276P046	WASHER #6 LOCK SS	6	EA
AMS5P094	SCREW 4-40 X 1/4 PHIL PAN	2	EA